

Assembled Ez2 Positioning/Operating Instructions

Step 1: Remove packaging material from unit. Report any damage to trucking company as soon as possible.

Step 2: Remove unit from skid. **NOTE** - Unit is **EXTREMELY HEAVY!** Use caution when moving. See *Figures A & B* for suggested method of removing from skid. Insert cardboard between hand truck & shelves to protect unit from scratching.

Step 3: Position unit in desired location with the lock towards the aisle. If positioning against a wall, allow a minimum clearance of 6" (7 1/2" for legal) for turning ability.

Step 4: Remove 2 shipping bolts from base (*Figure C*). Unlock unit if necessary. Please keep shipping bolts in the future event of moving the unit, as they must be reinserted to prevent damage to the unit!

****WARNING****

Moving unit without shipping bolts inserted may cause damage to unit & void warranty!

Step 5: Leveling unit. Turn rotating section of unit approximately a 1/4 turn to expose 4 glide access holes (*Figure D*). Then using a flat blade screw driver, adjust glides until unit is level.

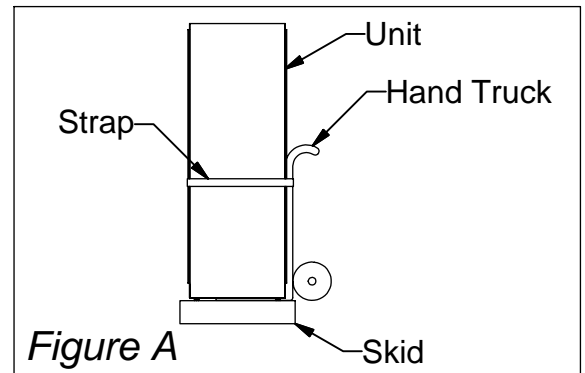

CAUTION

Do not use hand truck on end panel sides!

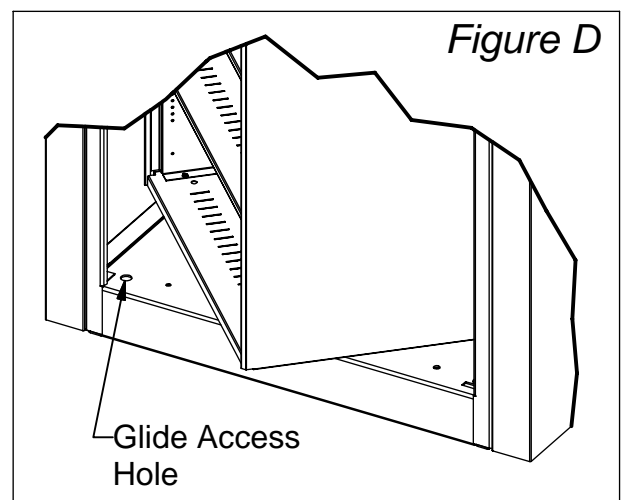
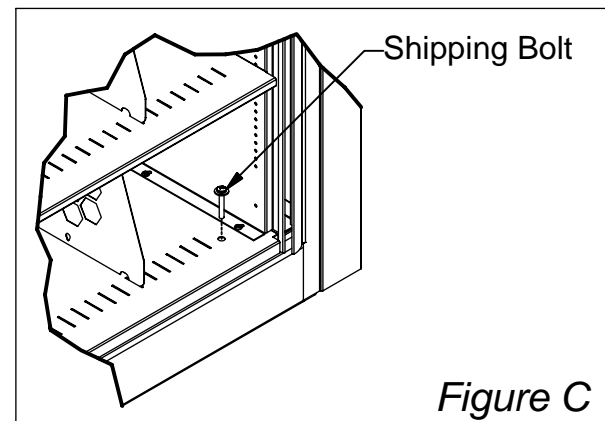
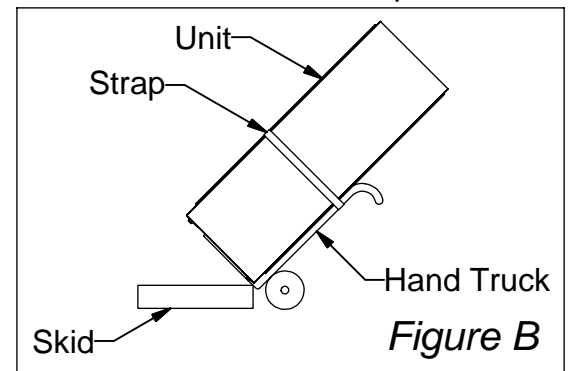

Assembled Ez2 Positioning/Operating Instructions

Step 6: Adjusting shelves. Should it be necessary to move shelves from standard location, first unload shelf, then loosen the four screws holding shelf in place. With screws loosened, tip rear of shelf up then pull shelf forward & up (*Figure E*). After removing the shelf, the screws can be removed as well. To reinstall shelf, start four screws into desired mounting holes, but do not tighten at this time. Install shelf by holding at angle & sliding over front two screws. Then tip shelf down engaging rear two screws & tighten.

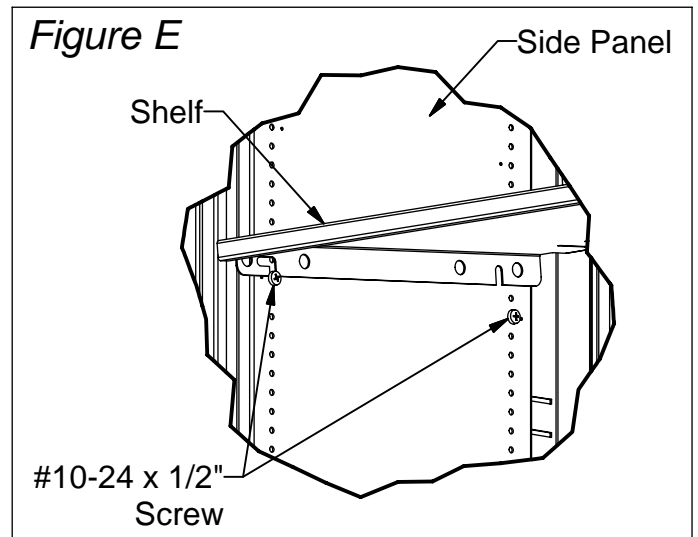

Step 7: Installing dividers (*Figure F*). Hook front tab into shelf first. Then slide divider back & hook top rear tab into back of shelf.

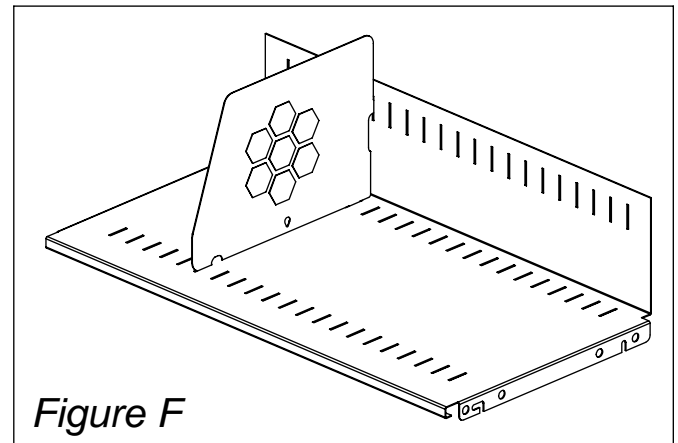

Step 8: Unit is now ready to use.

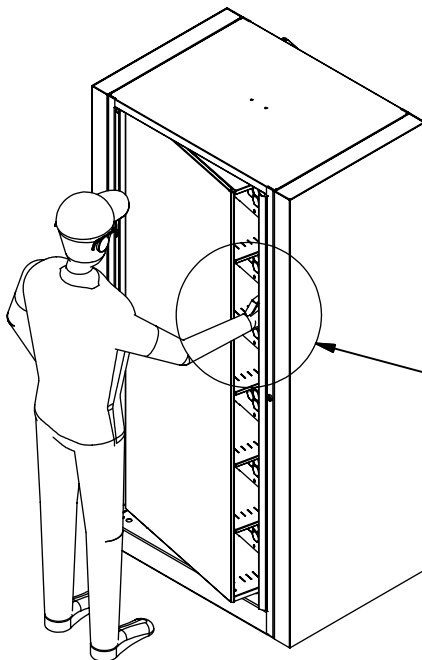

****WARNING****

*Do not attempt to lock unit while it is in motion.
This can damage lock & void warranty.
Do not stick body parts in unit while spinning.
This may cause bodily damage.*

If you need assembly assistance, please contact Customer Service at:
1-866-217-0330 (Monday through Friday 8:00 A.M. - 5:00 P.M. E.S.T.)